

# How to make a diary by JAN

Step 1: Cut Your paper. The size must be 20cm wide and 16cm high.

Step 2: Preage the pages. I prefer coffee, which I boil in to half amount. Soak the pages, and make sure that they dry under pressure. Otherwise they will wrinkle quite bad. However You might want to have a look at the ["Step 6: Additional aging"](#) at the Web-page.

Step 3: Fold and stack the dry pages. You´ll need about 10 stacks with 6 folded

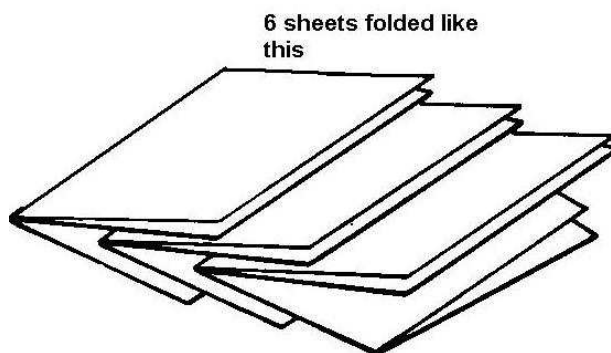

sheets and 2 stacks with 5 folded sheets. See ill. 1

Step 4: Sew the pages together. Use a strong, thin, off-white tread. See ill. 2

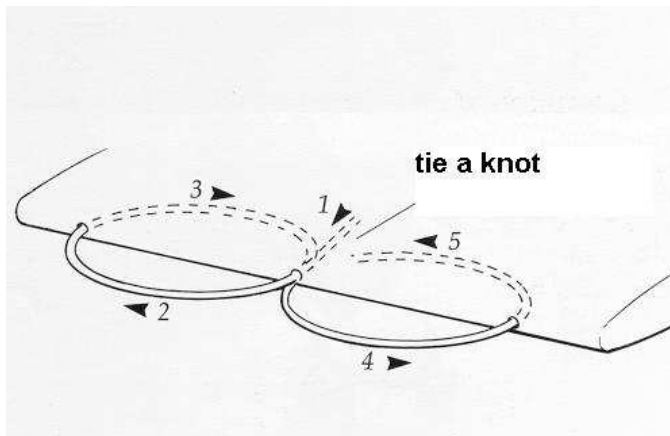

Step 5: Adjust the size, by cutting the pages again. Make sure that they do have the same size. If possible use a paper-cutter.

Step 6: Now make sure that pages/stacks are straight, and put them under pressure. But make sure that You can get to work with the back of the book. See fig. 3

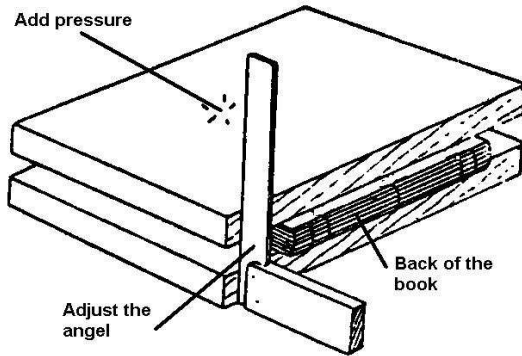

Step 7: Cut fabric for holding the back. See fig. 4

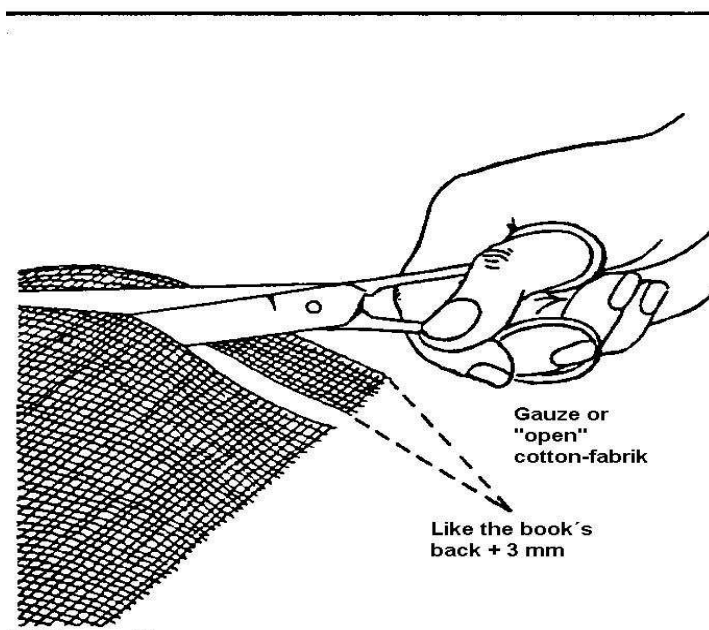
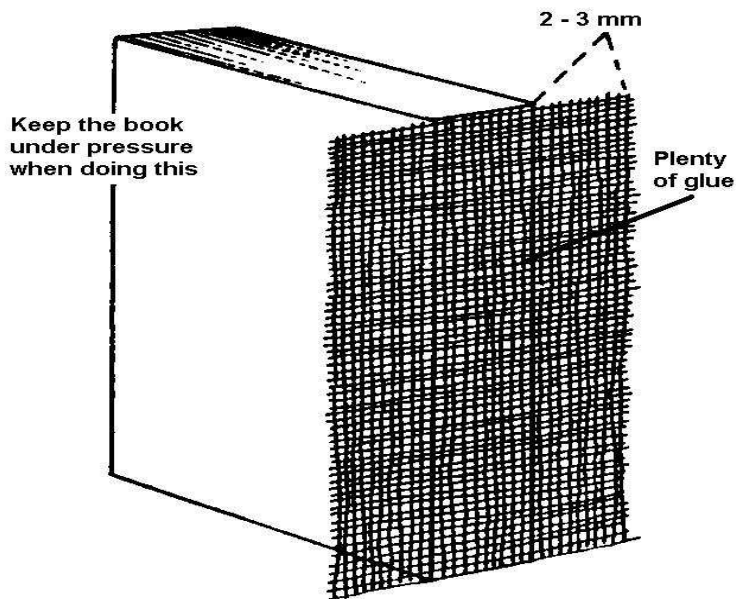

Fig. 4

Step 8: Glue the gauze or fabric to the back of the book. Use plenty of glue!  
White carpenter-gluе will do fine.  
See fig. 5



Step 9: Cut the cardboard. Two are needed. See fig. 6

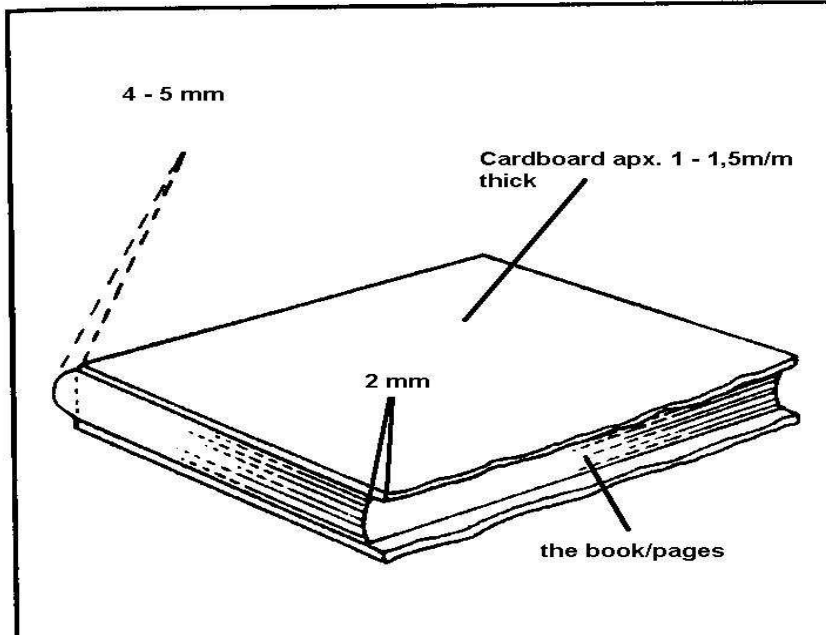
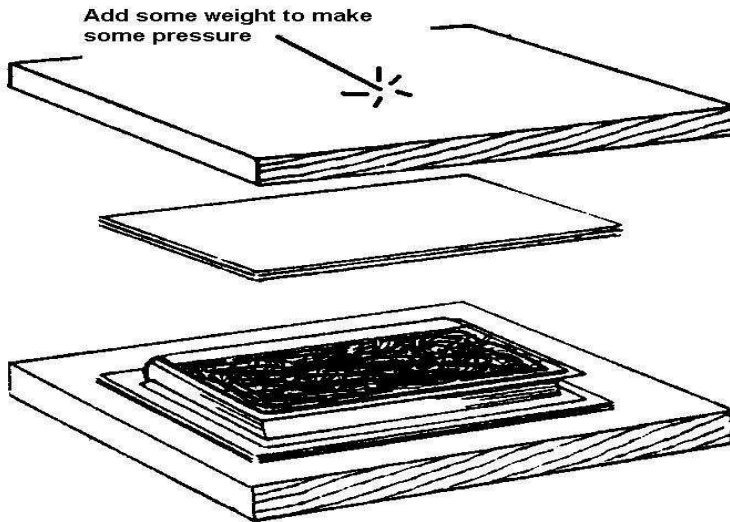

Fig. 6

Step 10: Glue the cardboard to the book, using first and last page. Make sure it's glued all over! Then keep the book under pressure for a day or so.

See fig. 7



Step 11: Then it's time to work the leather-cover. Here is how to get the right size. See fig. 8

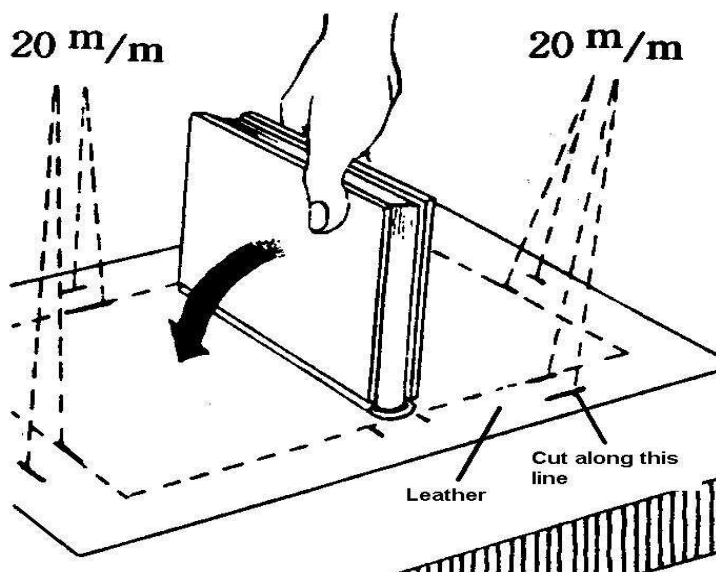

Step 12 : When you have cut the leather in the right size, add glue on the inside of the leather. And make sure there is plenty, and that the glue covers all the leather – don't forget the edges.

The leather should be thin and smooth in order to get a nice finish.

Place the back of the book in the middle, along the markings, and fold in the two sides on the leather like this. See fig. 9

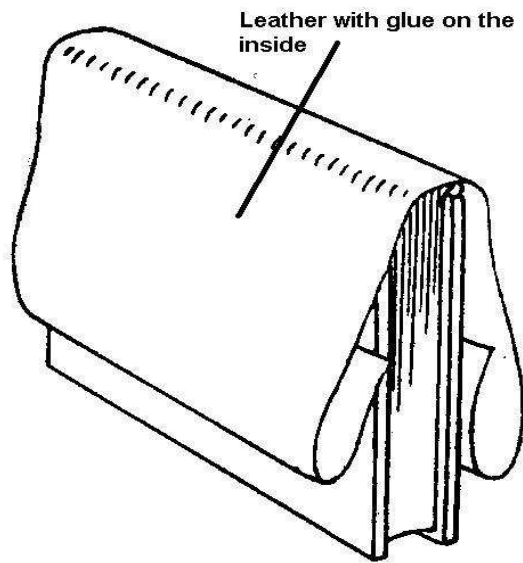

Step 13: Place the cover on one side at a time. See fig. 10

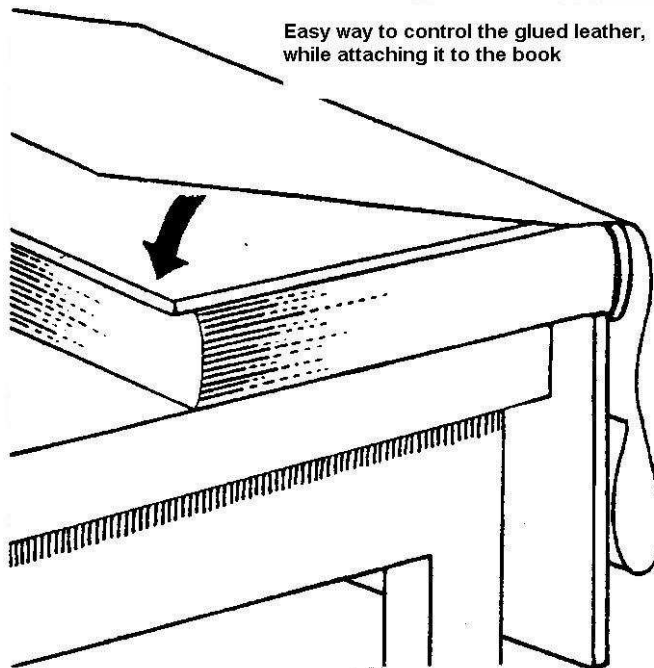

Step 14: Fold in the leather. Here is how to do the corners.  
See fig. 11.

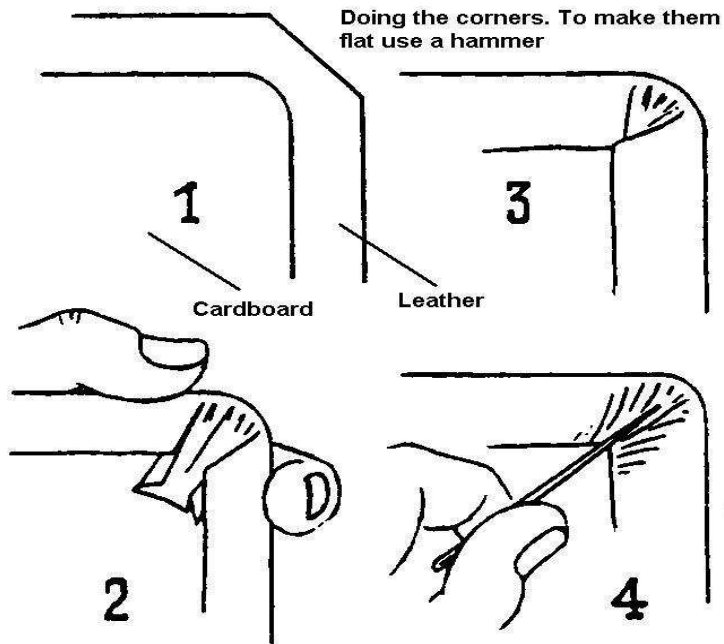

Step 15: Adjust the inside edges of the leather. Make it straight.  
See fig. 12

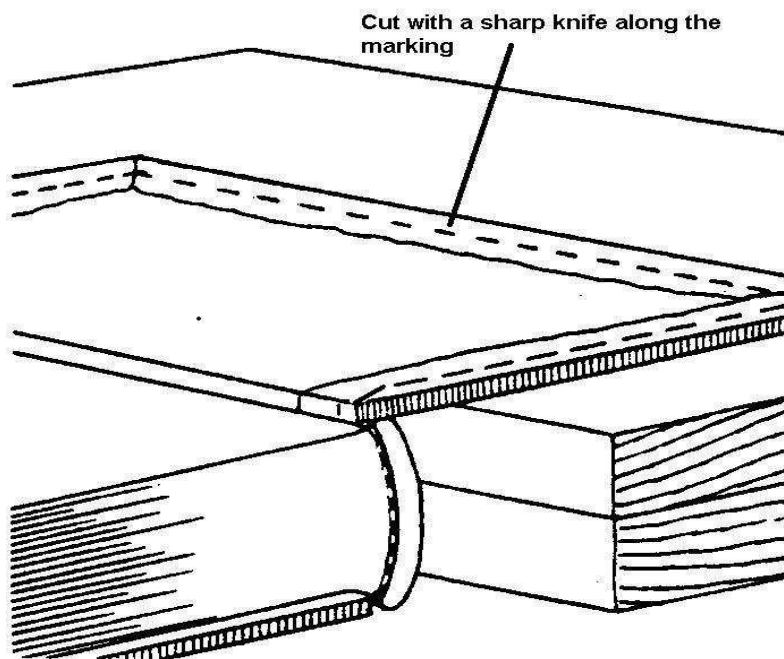

Step 16: Again, keep the book under pressure for 1 – 2 days.

Step 17: When it's completely dry, its time to do the inside finishing of the cover.  
When you add the glue, make sure to cover all the page – and use plenty.  
See fig. 13

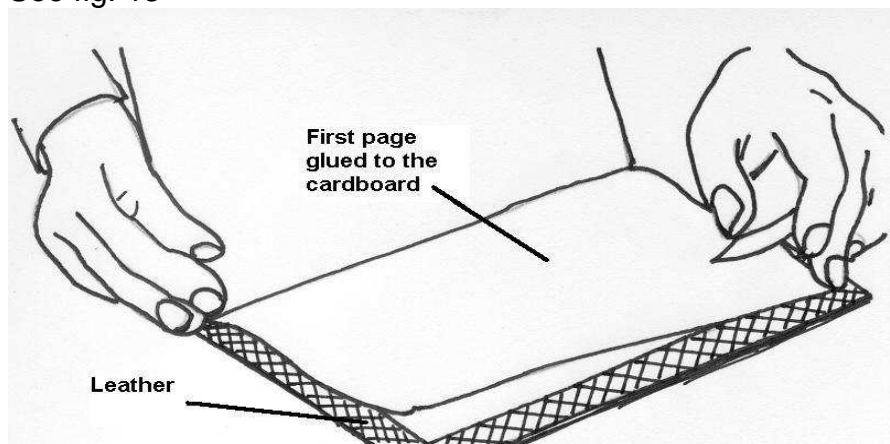

Step 18: adjust the pages. See fig. 14.

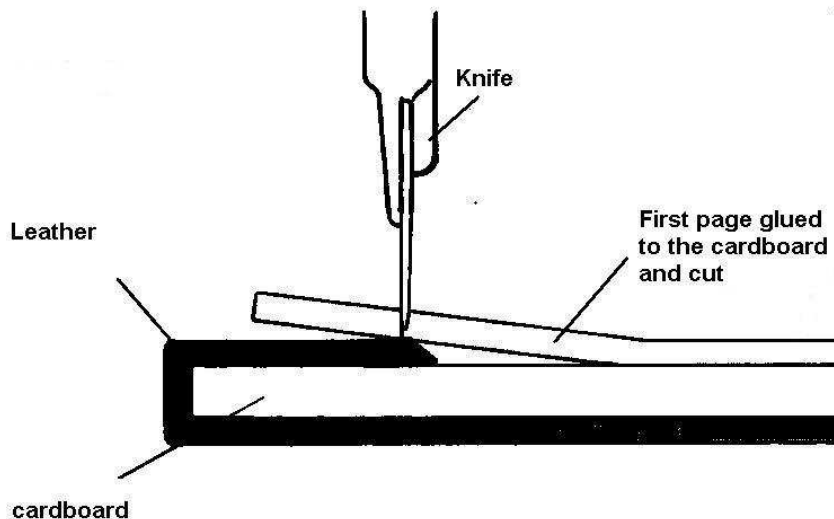

Step 19: When you have done front and back, the book goes back to pressure for at least a day.

Step 20: When it's dry it's time to preage the leather-cover. Use sandpaper, stones or whatever. But remember – make a "soft" start and add up, so that you are in control of the process.

**Congratulations! You just made your very own blank Grail Diary.**